

TABLE OF CONTENTS

ESL	HFR NUT – METRIC	
ESL	HFR NUT – STAINLESS STEEL	2
ESL	HFR NUT – UNC/UNF	3
ESL	HFR NUT ALL METALS – UNC/UNF – BS STANDARD	4
ERM	HFR FLANGE NUT WITH FREE WASHER – METRIC	5
ERM	HFR FLANGE NUT WITH FREE WASHER – UNC/UNF	6
THM	HFR NUT THIN TYPE	7
THU	HFR NUT STANDARD TYPE	8
HCB	HFR NUT HEIGHT = 0,8d	9
HCE	HFR NUT HEIGHT = d	10
HCT	HFR NUT HEIGHT (h) = 1,3d	11
ESF	HFR NUT RIVETING	12
HMP	HFR NUT NYLON INSERT – ISO 10511	13
HUP	HFR NUT NYLON INSERT – ISO 7040	14
EUM	HFR FLANGE NUT WITH FREE WASHER AND NYLON INSERT	15
GSL	HFR NUT – ISO 7042	16
SRF	HFR FLANGE NUT ALL METALS	17
HHS HUS HMS	HFR NUT STARNUTS	18
MODULAR FIXTURES	STAINLESS STEEL CHANNEL	19
MODULAR FIXTURES	LIGHT ALLOY CHANNEL	20
SPR	HFR NUT SPRING STOP NUT	21
SPECIAL PRODUCTS		22-23



FOREWORD OF THE MANUFACTURER

To ensure a safe male/female clamping condition, it is important to consider a combination of the following parameters when designing controlled bolt joint assemblies using self locking nuts (HFR):

1. SELECTION OF THE CORRECT GRADE OF RAW MATERIAL
2. TIGHTENING TORQUE (Nm)
3. TENSION IN THE BOLT (KN)
4. PREVAILING TORQUE (Nm)
5. COEFFICIENT OF FRICTION
6. SURFACE TREATMENT

In order to achieve a security fastening in conformity with industry standards, the 6 points above must be respected.

The following technical sheets will aid you in the selection of the self-locking nut adapted to your requirements.



Definition: all metals reusable slotted self-locking hexagon nut standard to the NF E 25-411 and SNCF ST 001-02 FPn6

Threading: standard to ISO 965-2

Characteristic and performance test: steel ISO 898-2/NF EN ISO 2320

Manufacturing range: metric/inch, all diameters, coarse & fine pitch, special heights & A/F upon request



d	Pitch	s	h	m	FPn6
M 2	0,40	4,00	4,50	2,30	
M 2,5	0,45	5,00	4,50	2,30	
M 3	0,50	5,50	4,50	2,50	X
M 4	0,70	7,00	5,30	2,60	X
M 5	0,80	8,00	6,30	3,00	X
M 6	1,00	10,00	7,00	3,60	X
M 7	1,00	11,00	8,10	4,80	
M 8	1,25	13,00	8,80	4,80	X
M 10	1,50	16,00	11,00	6,00	X
M 12	1,75	18,00	13,00	7,20	X
M 14	2,00	21,00	15,00	8,40	X
M 16	2,00	24,00	18,70	11,50	X
M 18	2,50	27,00	20,00	11,50	X
M 20	2,50	30,00	21,00	12,00	X
M 22*	2,50	34,00*	21,50	12,50	X
M 24	3,00	36,00	25,50	15,40	X
M 27	3,00	41,00	28,00	17,00	X
M 30	3,50	46,00	31,50	18,50	X
M 33	3,50	50,00	32,00	18,70	X
M 36	4,00	55,00	34,50	19,50	X
M 39	4,00	60,00	37,00	20,50	X
M 42	4,50	65,00	39,50	23,00	X
M 45	4,50	70,00	43,00	24,00	X
M 48	5,00	75,00	46,00	25,00	X

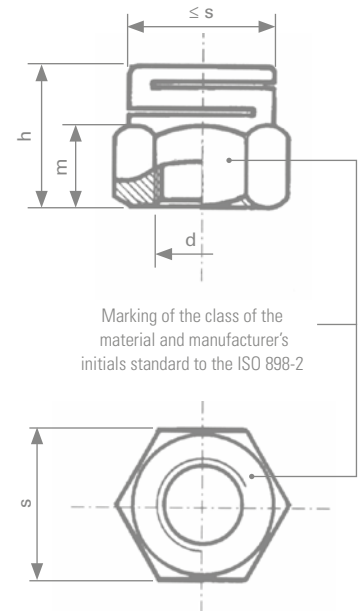

*Dimension of the hexagonal non standard

Quality class	Classification	Range of application
Class 8 steel	QV	Self-color -50° C + 300° C ⁽¹⁾
Class 10 steel	QK	
Class 12 steel	QL	

Others: Brass - Bronze - Light alloy - Titanium...

⁽¹⁾ Values are only given as an indication

Surface treatment (standard to ROHS requirements)

Electrolytic coating (steel)	Yellow	ZJ	ISO 4042
	White LANTHANE® Finish	ZL	ISO 4042
	White LANTHANE® Finish + Top coat	ZF	ISO 4042
Zinc lamellar (steel)			on request
Self Color		BT	

Example of ordering code

	Type	Diam x pitch	Class	Protection	
classification	ESL	100150	QV	ZF	00
wording	ESL	M10 x 1,50	8	Zinc LANTHANE® Top coat	*

*Standard size

Definition: all metals reusable slotted self-locking hexagon nut standard to the NF E 25-411 and SNCF ST 001-02 FPN6

Threading: standard to ISO 965-2

Characteristic and performance test: for stainless steel ISO 3506-2/NF E 25-035-2

Manufacturing range: metric/inch, all diameters, coarse & fine pitch, special heights & A/F upon request

d	Pitch	s	h	m	FPn6
M 2	0,40	4,00	4,50	2,30	
M 2,5	0,45	5,00	4,50	2,30	
M 3	0,50	5,50	4,50	2,50	X
M 4	0,70	7,00	5,30	2,60	X
M 5	0,80	8,00	6,30	3,00	X
M 6	1,00	10,00	7,00	3,60	X
M 7	1,00	11,00	8,10	4,80	
M 8	1,25	13,00	8,80	4,80	X
M 10	1,50	16,00	11,00	6,00	X
M 12	1,75	18,00	13,00	7,20	X
M 14	2,00	21,00	15,00	8,40	X
M 16	2,00	24,00	17,00	9,50	X
M 18	2,50	27,00	19,50	11,50	X
M 20	2,50	30,00	21,00	12,00	X
M 22*	2,50	34,00*	21,50	12,50	X
M 24	3,00	36,00	25,50	15,40	X
M 27	3,00	41,00	28,00	17,00	X
M 30	3,50	46,00	31,50	18,50	X
M 33	3,50	50,00	32,00	18,70	X
M 36	4,00	55,00	34,50	19,50	X
M 39	4,00	60,00	37,00	20,50	X
M 42	4,50	65,00	39,50	23,00	X
M 45	4,50	70,00	43,00	24,00	X
M 48	5,00	75,00	46,00	25,00	X

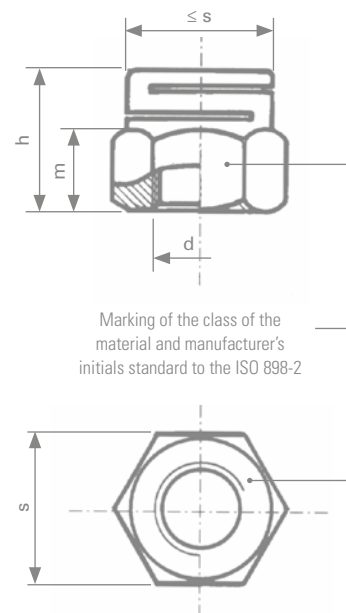

*Dimension of the hexagonal non standard

Quality class	Classification	Range of application
Stainless steel A2-70	ZE	Corrosive atmosphere -200° C + 400° C ⁽¹⁾
Stainless steel A4-70	ZK	
Stainless steel A4-80	ZH	

⁽¹⁾ Values are only given as an indication

Surface treatment (standard to ROHS requirements)

Surface treatment	Classification	Standard
Passivation	PA	NF EN 13811
Antigalling	ST	
	SH	
Self color	BT	

Example of ordering code

	Type	Diam x pitch	Class	Protection	
classification	ESL	M10 x 1,50	ZH	ST	00
wording	ESL	M10 x 1,50	A4 80	STANAL™400	*

*Standard size

Definition: all metals reusable slotted self-locking hexagon nut

Threading: series UNC/UNF ASME B1.1

Characteristic and performance test: steel ASME B18.16.6

Manufacturing range: metric/inch, all diameters, coarse & fine pitch, special heights & A/F upon request



d/inches	d/mm	Pitch/UNC	Pitch/UNF	s/mm	h/mm	m/mm	Codes
N°8	4,16	32	36	8,00	5,30	2,60	H
N°10	4,82	24	32	9,00	6,30	3,00	I
1/4	6,35	20	28	11,00	7,50	4,00	K
5/16	7,94	18	24	13,00	8,80	4,80	L
3/8	9,52	16	24	14,00	8,80	4,80	M
7/16	11,11	14	20	17,00	11,00	6,00	N
1/2	12,70	13	20	18,00	13,00	7,20	O
9/16	14,29	12	18	22,00	15,00	8,00	P
5/8	15,87	11	18	24,00	17,00	9,50	Q
3/4	19,05	10	16	28,00	21,00	12,00	R
7/8	22,22	9	14	33,00	22,00	12,50	S
1	25,40	8	12	41,00	24,00	13,50	T
1 1/4	31,75	7	12	46,00	29,50	16,00	V
1 1/2	38,10	6	12	55,00	32,00	17,50	X
1 3/4	44,45	5	-	on request			Z
2	50,80	4,5	-	75,00	46,00	25,50	Y

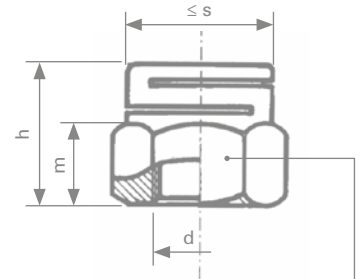

Marking of the class of the material and manufacturer's initials standard to the ISO 898-2

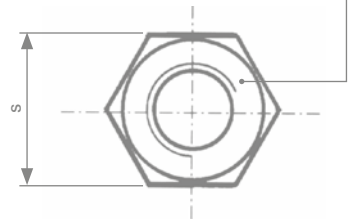

Quality class	Classification	Range of application
Grade 5/Grade B (class 8)	QV	Self color -50° C +300° C ⁽¹⁾
Grade 8/Grade C (class 10)	QK	
Stainless steel A2-70	ZE	Corrosive atmosphere -200° C +400° C ⁽¹⁾
Stainless steel A4-70	ZK	
Stainless steel A4-80	ZH	

Others: Brass - Bronze - Light alloy - Titanium...

⁽¹⁾ Values are only given as indication

Surface treatment (standard to ROHS requirements)

Electrolytic coating (steel)	Yellow	ZJ	ISO 4042
	White LANTHANE® Finish	ZL	ISO 4042
	White LANTHANE® Finish + Top coat	ZF	ISO 4042
Zinc lamellar (steel)		on request	
Antigalling (stainless steel)	STANAL™ 400	ST	
	Sherardisation	SH	NF EN 13811
Self Color		BT	

Example of ordering code

	Type	Diam x pitch	Class	Protection	
classification	ESL	N00UNC	QV	ZF	00
wording	ESL	ø 7/16" UNC	8	Zinc LANTHANE® Top coat	*

*Standard size

Definition: reusable slotted self-locking hexagon nut

Threading: series UNC/UNF ASME B1.1 and BS 84 - BSF/BSW on request

Characteristic and performance test: steel ASME B18.16.6 and BS 4929-2

Manufacturing range: metric/inch, all diameters, coarse & fine pitch, special heights & A/F upon request

d/inches	d/mm	Pitch/UNC	Pitch/UNF	s/min.	s/max.	h	m	codes
N°1	1,854	64	72	6,172	6,375	5,30	2,60	B
N°2	2,184	56	64	6,172	6,375	5,30	2,60	C
N°3	2,515	48	56	6,172	6,375	5,30	2,60	D
N°4	2,845	40	48	6,172	6,375	5,30	2,60	E
N°5	3,175	40	44	6,172	6,375	5,30	2,60	F
N°6	3,505	32	40	7,747	7,950	6,30	3,00	G
N°8	4,166	32	36	8,534	8,763	6,30	3,00	H
N°10	4,826	24	32	9,321	9,550	6,30	3,00	I
N°12	5,486	24	28	10,871	11,125	7,50	4,50	J
1/4	6,350	20	28	10,871	11,125	7,50	4,50	K
5/16	7,938	18	24	12,420	12,700	8,80	4,80	L
3/8	9,525	16	24	13,995	14,274	8,80	4,80	M
7/16	11,113	14	20	17,145	17,475	11,00	6,00	N
1/2	12,700	13	20	18,694	19,050	13,00	7,20	O
9/16	12,032	12	18	21,869	22,225	15,00	8,00	P
5/8	15,875	11	18	23,418	23,825	17,00	9,50	Q
3/4	19,050	10	16	27,635	28,575	21,00	12,00	R
7/8	22,225	9	14	32,232	33,324	22,00	12,50	S
1	25,400	8	12	36,830	38,100	24,00	13,50	T
1 1/8	28,575	7	12	41,427	42,875	25,00	14,00	U
1 1/4	31,750	7	12	46,024	47,701	29,50	16,00	V
1 3/8	34,925	6	12	50,647	52,374	32,00	17,00	W
1 1/2	38,100	6	12	55,245	57,150	35,00	18,50	X

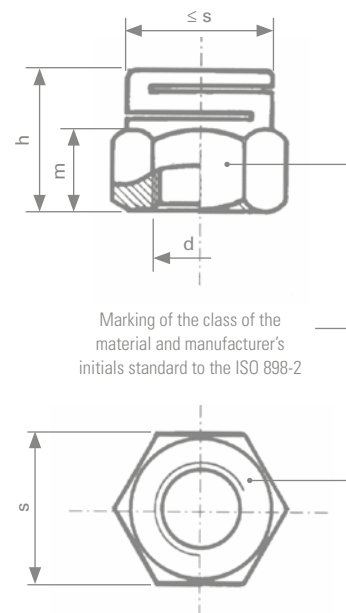

Quality class	Classification	Range of application
Grade 5/Grade B (class 8)	QV	Self color -50° C +300° C ⁽¹⁾
Grade 8/Grade C (class 10)	QK	
Stainless steel A2-70	ZE	Corrosive atmosphere -200° C +400° C ⁽¹⁾
Stainless steel A4-70	ZK	
Stainless steel A4-80	ZH	

Others: Brass - Bronze - Light alloy - Titanium...

⁽¹⁾ Values are only given as indication

Surface treatment (standard to ROHS requirements)				
Electrolytic coating (steel)	Yellow	ZJ		ISO 4042
	White LANTHANE®	ZL		ISO 4042
	White LANTHANE® Finish + Top coat	ZF		ISO 4042
Zinc lamellar (steel)			on request	
Antigalling (stainless steel)	STANAL™400	ST		
	Sherardisation	SH	NF EN 13811	
Self Color		BT		

Example of ordering code

	Type	Diam x pitch	Class	Protection	
classification	ESL	N00UNC	QV	ZF	00
	ESL	∅ 7/16" UNC	8	Zinc LANTHANE® Top coat	*

*Standard size

Definition: reusable slotted self-locking hexagon nut with free washer to SNCF ST 001-02 FPN15

Threading: standard to ISO 965-2

Characteristic and performance test: for steel ISO 898-2/ISO 2320

for stainless steel ISO 3506-2/NF E 25-035-2

Manufacturing range: metric/inch, all diameters, coarse & fine pitch, special heights & A/F upon request

d	Pitch	s	h max	m max	d ₂ *	s ₁ nominal	FPN15
M 4	0,70	7,00	7,30	2,70	12,00	1,10	
M 5	0,80	8,00	8,50	3,20	14,00	1,30	
M 6	1,00	10,00	10,10	4,60	18,00	1,40	X
M 8	1,25	13,00	11,80	4,90	22,00	1,60	X
M 10	1,50	16,00	14,80	6,30	22,00	1,80	X
M 10	1,50	16,00	14,80	6,30	27,00	1,80	X
M 12	1,75	18,00	16,50	7,40	27,00	1,80	X
M 14	2,00	21,00	19,30	8,60	30,00	2,40	X
M 16	2,00	24,00	22,10	9,70	40,00	3,20	
M 18	2,50	27,00	24,10	11,20	40,00	3,20	
M 20	2,50	30,00	26,20	12,20	40,00	3,20	
M 22	2,50	32,00	26,90	12,70	50,00	3,50	
M 24	3,00	36,00	29,00	15,10	55,00	4,00	

Sizes: * Only given as an indication. On request for other type and other diameter of washers

Quality class	Classification	Range of application
Class 8 steel	QV	Self color -50° C +300° C ⁽¹⁾
Class 10 steel	QK	
Stainless steel A2-70	ZE	Corrosive atmosphere -200° C +400° C ⁽¹⁾
Stainless steel A4-80	ZH	

Others: Brass - Bronze - Light alloy - Titanium

⁽¹⁾ Values are only given as indication

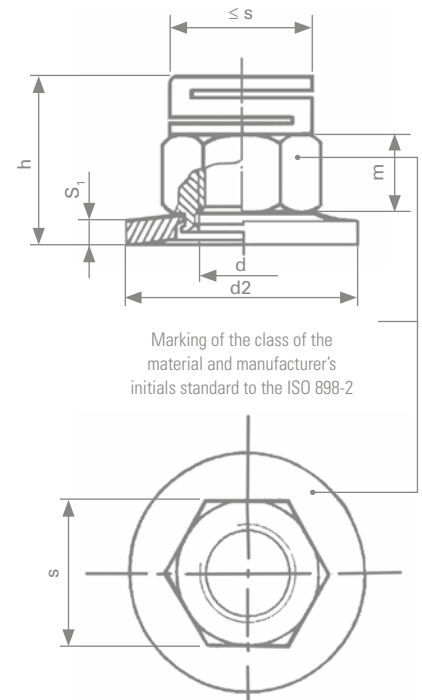

Surface treatment (standard to ROHS requirements)				
Electrolytic coating (steel)	Yellow	ZJ		ISO 4042
	White LANTHANE® Finish	ZL		ISO 4042
	White LANTHANE® Finish + Top coat	ZF		ISO 4042
Zinc lamellar (steel)			on request	
Antigalling (stainless steel)	STANAL™400	ST		
	Sherardisation	SH	NF EN 13811	
Self Color		BT		

Example of ordering code					
	Type	Diam x pitch	Class	Protection	
classification	ERM	100150	ZH	ST	01
wording	ERM	M10 x 1,50	A4 80	STANAL™400	CL22

*Standard size

Definition: all metals reusable slotted self-locking hexagon flange nut with free washer

Threading: series UNC/UNF ASME B1.1 and BS 84 - BSF/BSW on request

Characteristic and performance test: steel ASME B18.16.6 and BS 4929-2

Manufacturing range: metric/inch, all diameters, coarse & fine pitch, special heights & A/F upon request



d nominal	d/mm	Pitch/UNC	Pitch/UNF	s	h	m	d ₂ *	s ₁	codes
N°10	4,826	24	32	9,00	8,00	3,00	14,00	1,30	I
1/4	6,350	20	28	11,00	9,50	4,00	18,00	1,40	K
5/16	7,938	18	24	13,00	10,80	4,80	22,00	1,60	L
3/8	9,525	16	24	14,00	10,80	4,80	22,00	1,60	M
7/16	11,113	14	20	17,00	13,50	6,00	27,00	1,80	N
1/2	12,700	13	20	18,00	15,80	7,20	30,00	2,40	O
5/8	15,875	11	18	24,00	21,00	9,50	40,00	3,20	Q
3/4	19,050	10	16	28,00	25,00	12,00	40,00	3,20	R
7/8	22,225	8	12	38,00	28,70	13,5	50,00	4	T
1"	25,400	9	14	31,80	26,00	12,5	50,00	3	S

*Different type and diameter of washers can be supplied on request

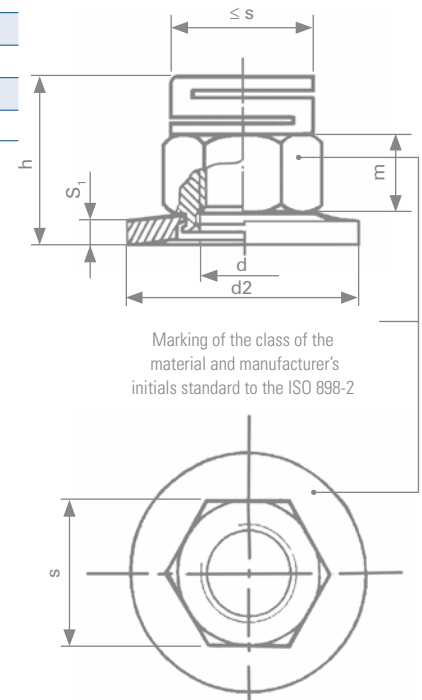

Quality class	Classification	Range of application
Grade 5/Grade B (Class 8)	QV	Self color -50° C +300° C ⁽¹⁾
Grade 8/Grade C (Class 10)	QK	
Stainless steel A2-70	ZE	Corrosive atmosphere -200° C +400° C ⁽¹⁾
Stainless steel A4-80	ZH	

⁽¹⁾ Values are only given as an indication

Surface treatment (standard to ROHS requirements)				
Electrolytic coating (steel)	Yellow	ZJ		ISO 4042
	White LANTHANE® Finish	ZL		ISO 4042
	White LANTHANE® Finish + Top coat	ZF		ISO 4042
Zinc lamellar (steel)			on request	
Antigalling (stainless steel)	STANAL™ 400	ST		
	Sherardisation	SH	NF EN 13811	
Self Color		BT		

Example of ordering code					
	Type	Diam x pitch	Class	Protection	
classification	ERM	N00UNF	QV	ZF	51
wording	ERM	ø 3/8 UNC	8	White LANTHANE® Top coat	CS22

*Standard size

Definition: all metals reusable two slotted self-locking hexagon nut

Threading: standard to ISO 965-2

Characteristic and performance test: for steel ISO 898-2/ISO 2320
for stainless steel ISO 3506-2/NF E 25-035-2

Manufacturing range: metric/inch, all diameters, coarse & fine pitch, special heights & A/F upon request



d nominal	Pitch	h	m	s
M 4	0,70	4,50	2,50	7,00
M 5	0,80	4,80	2,60	8,00
M 6	1,00	5,20	2,70	10,00
M 8	1,25	6,00	3,50	13,00
M 10	1,50	7,50	4,50	17,00
M 12	1,75	9,00	5,50	19,00
M 14	2,00	11,00	7,00	22,00
M 16	2,00	12,00	8,00	24,00
M 18	2,50	14,00	9,50	27,00
M 20	2,50	15,00	10,50	30,00
M 22*	2,50	17,00	12,00	34,00
M 24	3,00	19,00	13,00	36,00
M 27	3,00	20,00	14,00	41,00
M 30	3,50	21,50	15,00	46,00
M 33	3,50	23,00	16,50	50,00
M 36	4,00	25,00	18,00	55,00
M 39	4,00	26,00	19,00	60,00
M 42	4,50	30,00	22,00	65,00
M 45	4,50	32,00	24,00	70,00

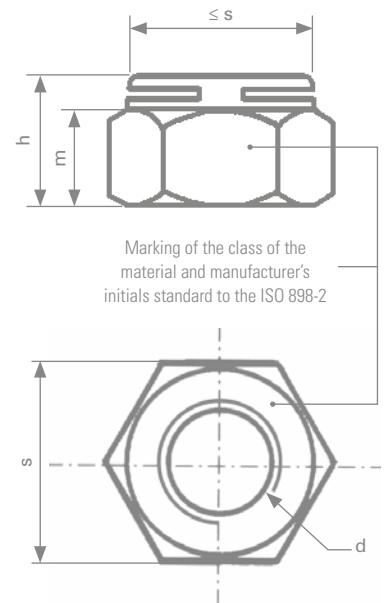

*Dimension of the hexagonal non standard

Quality class	Classification	Range of application
Class 04 steel (Class8)	QN	Self color -50° C +300° C ⁽¹⁾
Class 05 steel (Class 10)	QS	
Stainless steel A2-035 (A2-70)	ZEB	Corrosive atmosphere -200° C +400° C ⁽¹⁾
Stainless steel A4-035 (A4-70)	ZKB	
Stainless steel A4-040 (A4-80)	ZHB	

⁽¹⁾ Values are only given as an indication

Surface treatment (standard to ROHS requirements)

Electrolytic coating (steel)	Yellow	ZJ	ISO 4042
	White LANTHANE® Finish + Top coat	ZL	ISO 4042
	White LANTHANE® Finish + Top coat	ZF	ISO 4042
Zinc lamellar (steel)		on request	
Antigalling (stainless steel)	STANAL™400	ST	
	Sherardisation	SH	NF EN 13811
Self Color		BT	

Example of ordering code

	Type	Diam x pitch	Class	Protection	
classification	THM	100150	ZH	ST	00
	THM	M10 x 1,50	A4 80	STANAL™400	*

*Standard size

Definition: all metals reusable two slotted self-locking hexagon nut

Threading: standard to ISO 965-2

Characteristic and performance test: for steel ISO 898-2/ISO 2320

for stainless steel ISO 3506-2/NF E 25-035-2

Manufacturing range: metric/inch, all diameters, coarse & fine pitch, special heights & A/F upon request



d nominal	Pitch	h	m	s
M 4	0,70	5,50	3,50	7,00
M 5	0,80	6,50	4,30	8,00
M 6	1,00	7,50	5,00	10,00
M 8	1,25	8,50	6,00	13,00
M 10	1,50	11,00	8,00	17,00
M 12	1,75	13,00	9,50	19,00
M 14	2,00	15,00	11,00	22,00
M 16	2,00	17,00	13,00	24,00
M 18	2,50	20,00	15,50	27,00
M 20	2,50	22,00	17,50	30,00
M 22*	2,50	23,00	18,00	34,00*
M 24	3,00	25,00	19,00	36,00
M 27	3,00	27,00	21,00	41,00
M 30	3,50	30,00	23,50	46,00
M 33	3,50	33,00	26,50	50,00
M 36	4,00	36,00	29,00	55,00
M 39	4,00	38,00	31,00	60,00
M 42	4,50	42,00	34,00	65,00
M 45	4,50	45,00	37,00	70,00

*Dimension of the hexagonal non standard

Quality class	Classification	Range of application
Class 8 steel	QV	Self color -50° C +300° C ⁽¹⁾
Class 10 steel	QK	
Class 12 steel	QL	
Stainless steel A2-70	ZE	Corrosive atmosphere -200° C +400° C ⁽¹⁾
Stainless steel A4-70	ZK	
Stainless steel A4-80	ZH	

⁽¹⁾ Values are only given as an indication

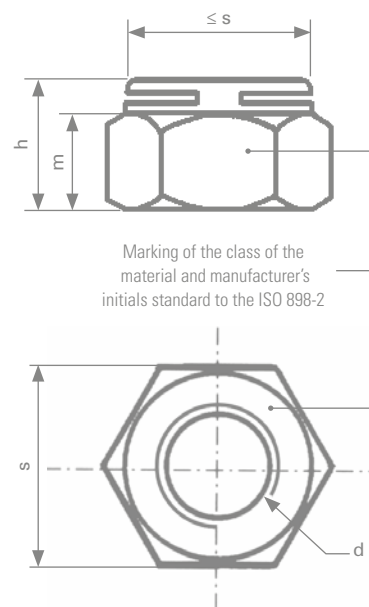

Surface treatment (standard to ROHS requirements)

Electrolytic coating (steel)	Yellow	ZJ	ISO 4042
	White LANTHANE® Finish	ZL	ISO 4042
	White LANTHANE® Finish + Top coat	ZF	ISO 4042
Zinc lamellar (steel)		on request	
Antigalling (stainless steel)	STANAL™400	ST	
	Sherardisation	SH	NF EN 13811
Self Color		BT	

Example of ordering code

	Type	Diam x pitch	Class	Protection	
classification	THU	100150	ZH	ST	00
wording	THU	M10 x 1,50	A4 80	STANAL™400	*

*Standard size

HCB

HFR NUT

HEIGHT = 0,8d

Definition: all metals self-locking hexagon nut with one slot

Threading: standard to ISO 965-2

Characteristic and performance test: for steel ISO 898-2/ISO 2320

for stainless steel ISO 3506-2/NF E 25-035-2

Manufacturing range: metric/inch, all diameters, coarse & fine pitch, special heights & A/F upon request

d	Pitch	h - min.	h - max.	s
M 5	0,80	3,70	4,70	8,00
M 6	1,00	4,70	5,20	10,00
M 8	1,25	6,14	6,80	13,00
M 10	1,50	7,64	8,40	16,00
M 12	1,75	9,50	10,80	18,00
M 14	2,00	10,30	12,80	21,00
M 16	2,00	12,30	14,80	24,00
M 18	2,50	14,20	15,80	27,00
M 20	2,50	14,90	18,00	30,00
M 22*	2,50	16,90	19,40	34,00*
M 24	3,00	17,70	21,50	36,00
M 27	3,00	20,70	23,80	41,00
M 30	3,50	22,70	25,60	46,00
M 33	3,50	24,70	28,70	50,00
M 36	4,00	27,40	31,00	55,00
M 39	4,00	29,40	33,40	60,00
M 42*	4,50	32,40	34,00	65,00
M 45*	4,50	34,40	36,30	70,00
M 48*	5,00	36,40	38,70	75,00

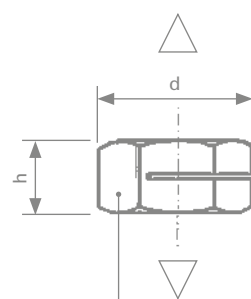

Marking of the class of the material and manufacturer's initials standard to the ISO 898-2

△ Assembly direction

*Dimension of the hexagonal non standard

* Nonstandard, agreement between customer and supplier

Quality class	Classification	Range of application
Class 04 steel (Class8)	QN	Self color -50° C +300° C ⁽¹⁾
Class 05 steel (Class10)	QS	
Stainless steel A2-035 (A2-70)	ZEB	Corrosive atmosphere -200° C +400° C ⁽¹⁾
Stainless steel A4-035 (A4-70)	ZKB	
Stainless steel A4-040 (A4-80)	ZHB	

⁽¹⁾ Values are only given as an indication

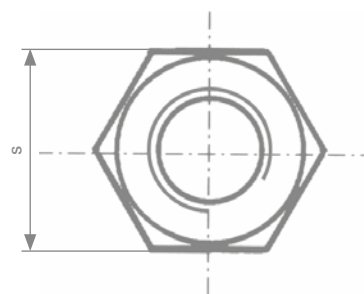

Surface treatment (standard to ROHS requirements)

Electrolytic coating (steel)	Yellow	ZJ	ISO 4042
	White LANTHANE® Finish	ZL	ISO 4042
	White LANTHANE® Finish + Top coat	ZF	ISO 4042
Zinc lamellar (steel)			on request
Antigalling (stainless steel)	STANAL™400	ST	
	Sherardisation	SH	NF EN 13811
Self Color		BT	

Example of ordering code

	Type	Diam x pitch	Class	Protection	
classification	HCB	M10 x 1,50	ZH	ST	00
wording	HCB	M10 x 1,50	A4 80	STANAL™400	*

*Standard size

HCE

HFR NUT

HEIGHT = d

Definition: all metals self-locking hexagon nut with one slot

Threading: standard to ISO 965-2

Characteristic and performance test: for steel ISO 898-2/ISO 2320

for stainless steel ISO 3506-2/NF E 25-035-2

Manufacturing range: metric/inch, all diameters, coarse & fine pitch, special heights & A/F upon request

d	Pitch	h - min.	h - max.	s
M 4	0,70	3,90	4,10	7,00
M 5	0,80	4,80	5,10	8,00
M 6	1,00	5,40	6,00	10,00
M 8	1,25	7,14	8,00	13,00
M 10	1,50	8,94	10,00	16,00
M 12	1,75	11,57	12,00	18,00
M 14	2,00	13,40	14,10	21,00
M 16	2,00	15,70	16,40	24,00
M 18	2,50	16,90	18,00	27,00
M 20	2,50	19,00	20,30	30,00
M 22	2,50	20,50	22,00	34,00
M 24	3,00	22,60	24,00	36,00
M 27	3,00	25,40	27,00	41,00
M 30	3,50	27,30	30,00	46,00
M 33	3,50	30,90	33,00	50,00
M 36	4,00	33,10	36,00	55,00
M 39	4,00	35,90	40,40	60,00
M 42	4,50	36,60	43,40	65,00
M 45	4,50	38,90	46,40	70,00
M 48	5,00	41,20	49,40	75,00

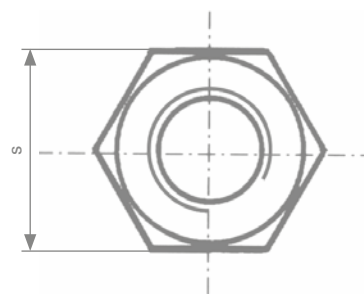
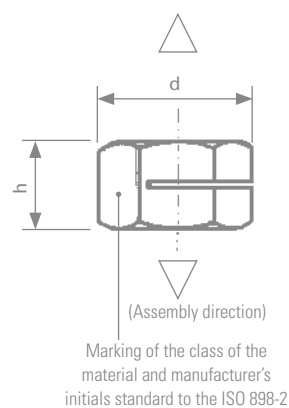

Quality class	Classification	Range of application
Class 8 steel	QV	Self color -50° C +300° C ⁽¹⁾
Class 10 steel	QK	
Class 12 steel	QL	
Stainless steel A2-70	ZE	Corrosive atmosphere -200° C +400° C ⁽¹⁾
Stainless steel A4-70	ZK	
Stainless steel A4-80	ZH	

⁽¹⁾ Values are only given as an indication

Surface treatment (standard to ROHS requirements)

Electrolytic coating (steel)	Yellow	ZJ	ISO 4042
	White LANTHANE® Finish	ZL	ISO 4042
	White LANTHANE® Finish + Top coat	ZF	ISO 4042
Zinc lamellar (steel)			on request
Antigalling (stainless steel)	STANAL™400	ST	
	Sherardisation	SH	NF EN 13811
Self Color		BT	

Example of ordering code

	Type	Diam x pitch	Class	Protection	
classification	HCE	100150	ZH	ST	00
wording	HCE	M10 x 1,50	A4 80	STANAL™400	*

*Standard size

Definition: all metals self-locking hexagon nut with one slot to SNCF ST 001-02 FPN5

Threading: standard to ISO 965-2

Characteristic and performance test: for steel ISO 898-2/ISO 2320

for stainless steel ISO 3506-2/NF E 25-035-2

Manufacturing range: metric/inch, all diameters, coarse & fine pitch, special heights & A/F upon request

d	Pitch	h - min.	h - max.	s	FPn5
M 3	0,50	3,80	4,00	5,50	X
M 4	0,70	5,10	5,30	7,00	X
M 5	0,80	6,20	6,70	8,00	X
M 6	1,00	7,60	8,00	10,00	X
M 8	1,25	10,20	10,60	13,00	X
M 10	1,50	12,75	13,25	16,00	X
M 12	1,75	15,35	15,85	18,00	X
M 14	2,00	18,00	18,40	21,00	X
M 16	2,00	20,60	21,00	24,00	X
M 18	2,50	23,20	23,60	27,00	X
M 20	2,50	25,80	26,20	30,00	X
M 22*	2,50	28,40	28,80	34,00*	X
M 24	3,00	31,00	31,40	36,00	X
M 27	3,00	34,90	35,30	41,00	X
M 30*	3,50	36,80	39,20	46,00	
M 33*	3,50	42,70	43,10	50,00	
M 36*	4,00	46,50	47,10	55,00	
M 39*	4,00	50,40	51,00	60,00	
M 42*	4,50	54,30	54,90	65,00	
M 45*	4,50	58,20	58,80	70,00	
M 48*	5,00	62,10	62,70	75,00	

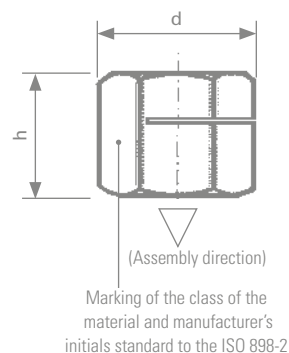

*Dimension of the hexagonal non standard

Quality class	Classification	Range of application
Class 8 steel	QV	Self color -50° C +300° C ⁽¹⁾
Class 10 steel	QK	
Class 12 steel	QL	
Stainless steel A2-70	ZE	Corrosive atmosphere -200° C +400° C ⁽¹⁾
Stainless steel A4-70	ZK	
Stainless steel A4-80	ZH	

⁽¹⁾ Values are only given as an indication

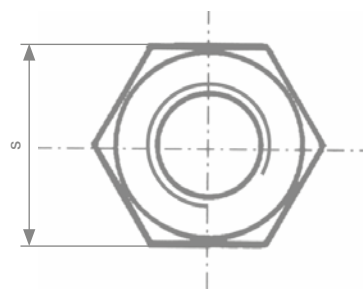

Surface treatment (standard to ROHS requirements)

Electrolytic coating (steel)	Yellow	ZJ	ISO 4042
	White LANTHANE® Finish	ZL	ISO 4042
	White LANTHANE® Finish + Top coat	ZF	ISO 4042
Zinc lamellar (steel)		on request	
Antigalling (stainless steel)	STANAL™400	ST	
	Sherardisation	SH	NF EN 13811
Self Color		BT	

Example of ordering code

	Type	Diam x pitch	Class	Protection	
classification	HCT	100150	ZH	ST	00
wording	HCT	M10 x 1,50	A4 80	STANAL™400	*

*Standard size

Definition: all metals self-locking riveting nut, with locking slot

Threading: standard to ISO 965-2

Characteristic and performance test: for steel ISO 898-2/ISO 2320

for stainless steel ISO 3506-2/NF E 25-035-2

Manufacturing range: metric/inch, all diameters, coarse & fine pitch, special heights & A/F upon request

d	s	J0 + 0,05	B	C	Sheet thickness	ø Boring
M 4	8,00	6,74	5,30	1,60	1,50	6,55
				2,20	2,00	to
				2,60	2,50	6,65
M 5	10,00	8,00	6,30	2,00	1,80	7,8 à 7,9
M 6	11,00	8,90	7,00	2,20	2,00	8,70
				2,60	2,50	to
				3,40	3,00	8,80
M 8	14,00	10,50	9,80	2,60	2,50	10,30
				3,40	3,00	
				4,20	4,00	
				6,20	5,80	
M 10	18,00	15,00	12,00	3,00	2,80	14,80 to
				6,00	5,80	14,90
M 12	21,00	18,00	14,00	3,00	2,80	17,8
				4,00	3,80	
				6,00	5,80	
M 16	27,00	24,20	17,00	3,00	2,80	24,00 to
				5,50	5,30	24,10
M 20	32,00	28,20	21,00	3,00	2,80	28,00 to
				5,50	5,30	

Sizes: The sheet thicknesses were given as examples, please contact us for other thicknesses

Quality class	Classification	Range of application
Class 8 steel	QV	Self color -50° C +300° C ⁽¹⁾
Stainless steel A4-80	ZH	Corrosive atmosphere -200° C +400° C ⁽¹⁾

⁽¹⁾ Values are only given as an indication

Surface treatment (standard to ROHS requirements)

Electrolytic coating (steel)	Yellow	ZJ	ISO 4042
	White LANTHANE®	ZL	ISO 4042
	White LANTHANE® Finish + Top coat	ZF	ISO 4042
Zinc lamellar (steel)		on request	
Antigalling (stainless steel)	STANAL™400	ST	
	Sherardisation	SH	NF EN 13811
Self Color		BT	

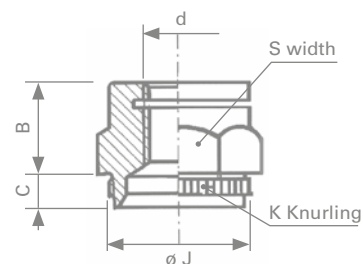

Assembly instruction



ESF riveting nut

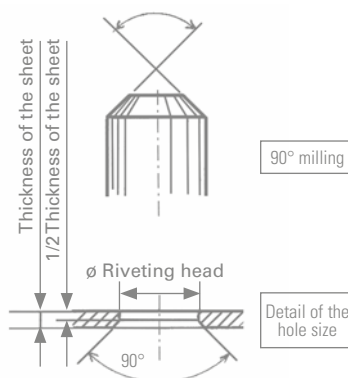

Example of ordering code

	Type	Diam x pitch	Class	Protection	
classification	ESF	060100	QV	ZF	26
wording	ESF	M6 x 1,00	8	White LANTHANE® Top coat	2,6*

*Sheet thickness

Definition: self-locking nut with nylon insert to SNCF ST 001-02 FPN2

Threading: standard to ISO 965-2

Characteristic and performance test: for steel ISO 898-2/ISO 2320
for stainless steel ISO 3506-2/NF E 25-035-2

Manufacturing range: metric/inch, all diameters, coarse & fine pitch, special heights & A/F upon request

d	Pitch	h - min.	h - max.	m - min.	s	FPn2
M 3	0,50	3,42	3,90	1,55	5,50	
M 4	0,70	4,52	5,00	1,95	7,00	X
M 5	0,80	4,52	5,00	2,45	8,00	X
M 6	1,00	5,52	6,00	2,90	10,00	X
M 8	1,25	6,18	6,76	3,70	13,00	X
M 10	1,50	7,98	8,56	4,70	16,00	X
M 12	1,75	9,53	10,23	5,70	18,00	X
M 14	2,00	10,22	11,32	6,42	21,00	X
M 16	2,00	11,32	12,42	7,42	24,00	X
M 18*	2,50	13,10	14,90	9,00	27,00	X
M 20	2,50	14,40	15,50	9,10	30,00	X
M 22*	2,50	16,50	17,60	11,00	34,00	X
M 24	3,00	16,00	17,80	10,90	36,00	X
M 27*	3,00	20,40	22,20	13,50	41,00	X
M 30	3,50	20,10	22,20	13,90	46,00	X
M 33*	3,50	25,00	26,20	16,50	50,00	X
M 36	4,00	23,40	25,50	16,90	55,00	X

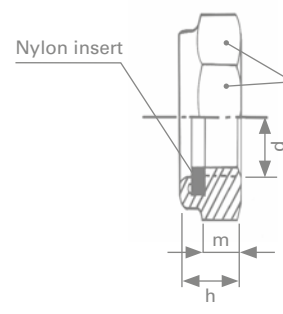

Marking of the class of the material and manufacturer's initials standard to the ISO 898-2

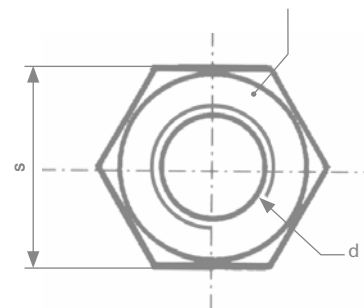

*These dimensions do not respond to the 10511

Quality class	Classification	Range of application	
Class 04 steel (Class8)	QN	Usual ring	Brown ring ⁽²⁾
Class 05 steel (Class10)	QS		
Stainless steel A2-035 (A2-70)	ZEB	-40° C +120° C ⁽¹⁾	-40° C +230° C ⁽¹⁾
Stainless steel A4-035 (A4-70)	ZKB		
Stainless steel A4-040 (A4-80)	ZHB		

⁽¹⁾ Values are only given as an indication ⁽²⁾ Ordering code B06

Surface treatment (standard to ROHS requirements)

Electrolytic coating (steel)	Yellow	ZJ		ISO 4042
	White LANTHANE [®] Finish	ZL		ISO 4042
	White LANTHANE [®] Finish + Top coat	ZF		ISO 4042
Zinc lamellar (steel)			on request	
Antigalling (stainless steel)	STANAL [™] 400	ST		
	Sherardisation	SH	NF EN 13811	
Self Color		BT		

Example of ordering code

	Type	Diam x pitch	Class	Protection	
classification	HMP	M10 x 1,50	A4 80	STANAL [™] 400	*
	HMP	M10 x 1,50	ZH	ST	00

*Standard size

Definition: self-locking nut with nylon insert to SNCF ST 001-02 FpN1

Threading: standard to ISO 965-2

Characteristic and performance test: for steel ISO 898-2/ISO 2320

for stainless steel ISO 3506-2/NF E 25-035-2

Manufacturing range: metric/inch, all diameters, coarse & fine pitch, special heights & A/F upon request

d	Pitch	h - min.	h - max.	m - min.	s	FpN1
M 3	0,50	4,02	4,50	2,15	5,50	X
M 4	0,70	5,52	6,00	2,90	7,00	X
M 5	0,80	6,22	6,80	4,40	8,00	X
M 6	1,00	7,42	8,00	4,90	10,00	X
M 8	1,25	8,92	9,50	6,44	13,00	X
M 10	1,50	11,20	11,90	8,04	16,00	X
M 12	1,75	14,20	14,90	10,37	18,00	X
M 14	2,00	15,90	17,00	12,10	21,00	X
M 16	2,00	17,80	19,10	14,10	24,00	X
M 18	2,50	21,00	22,30	15,10	27,00	X
M 20	2,50	20,70	22,80	16,90	30,00	X
M 22	2,50	24,90	26,00	18,10	34,00	X
M 24	3,00	25,00	27,10	20,20	36,00	X
M 27	3,00	30,40	32,50	22,50	41,00	X
M 30	3,50	30,10	32,60	24,30	46,00	X
M 33	3,50	35,90	38,40	27,40	50,00	X
M 36	4,00	36,40	38,90	29,40	55,00	X
M 39	4,00	42,20	44,70	31,80	60,00	X
M 42	4,50	44,80	47,50	32,40	65,00	X

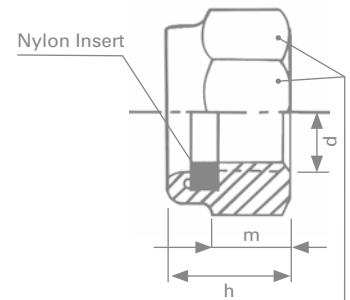

Marking of the class of the material and manufacturer's initials standard to the ISO 898-2

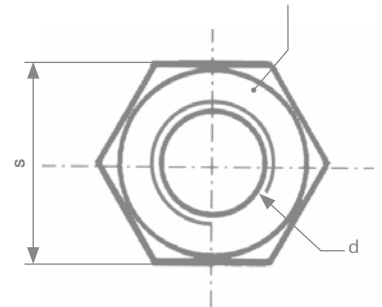

Quality class	Classification	Range of application	
Class 8 steel	QV	Usual ring	Brown ring ⁽²⁾
Class 10 steel	QK	-40° C +120° C ⁽¹⁾	-40° C +230° C ⁽¹⁾
Stainless steel A2-70	ZE		
Stainless steel A4-70	ZK		
Stainless steel A4-80	ZH		

⁽¹⁾ Values are only given as an indication ⁽²⁾ Ordering code B06

Surface treatment (standard to ROHS requirements)

Electrolytic coating (steel)	Yellow	ZJ		ISO 4042
	White LANTHANE® Finish	ZL		ISO 4042
	White LANTHANE® Finish + Top coat	ZF		ISO 4042
Zinc lamellar (steel)			on request	
Antigalling (stainless steel)	STANAL™400	ST		
	Sherardisation	SH	NF EN 13811	
Self Color		BT		

Example of ordering code

	Type	Diam x pitch	Class	Protection	
classification	HUP	M10 x 1,50	ZH	ST	00
wording	HUP	M10 x 1,50	A4 80	STANAL™400	*

*Standard size

Definition: all metals reusable slotted self-locking hexagon nut with free washer and nylon insert

Threading: standard to ISO 965-2

Characteristic and performance test: for steel ISO 898-2/ISO 2320

for stainless steel ISO 3506-2/NF E 25-035-2

Manufacturing range: metric/inch, all diameters, coarse & fine pitch, special heights & A/F upon request

d	Pitch	s	h	m	d ₂ *	s ₁
M 4	0,70	7,00	7,70	3,30	12,00	1,10
M 5	0,80	8,00	8,70	4,50	14,00	1,30
M 6	1,00	10,00	10,10	5,60	18,00	1,40
M 8	1,25	13,00	12,00	7,30	22,00	1,60
M 10	1,50	16,00	14,80	8,40	27,00	1,80
M 12	1,75	18,00	18,40	11,40	27,00**	1,80
M 12	1,75	18,00	18,40	11,40	30,00**	1,80
M 14	2,00	21,00	20,50	13,30	32,00	2,40
M 16	2,00	24,00	23,70	14,20	40,00	3,20

Sizes: *Only given as an indication. On request for other type and other diameter of washers

**Stainless steel for diameter 27; steel for diameter 30.

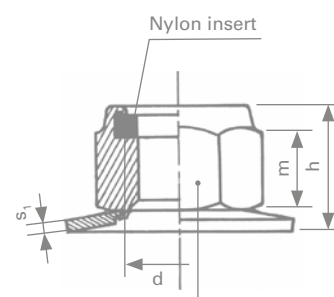

Marking of the class of the material and manufacturer's initials standard to the ISO 898-2

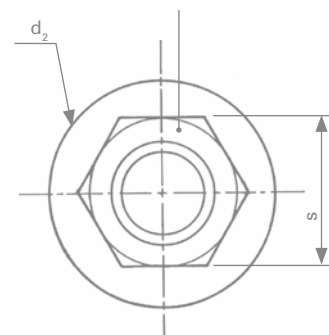

Quality class	Classification	Range of application
Class 8 steel	QV	Self color -40° C +120° C ⁽¹⁾
Class 10 steel	QK	
Stainless steel A2-70	ZE	
Stainless steel A4-80	ZH	

⁽¹⁾ Values are only given as an indication

Surface treatment (standard to ROHS requirements)

Electrolytic coating (steel)	Yellow	ZJ	ISO 4042
	White LANTHANE® Finish	ZL	ISO 4042
	White LANTHANE® Finish + Top coat	ZF	ISO 4042
Zinc lamellar (steel)		on request	
Antigalling (stainless steel)	STANAL™400	ST	
	Sherardisation	SH	NF EN 13811
Self Color		BT	

Example of ordering code

	Type	Diam x pitch	Class	Protection	
classification	EUM	100150	ZH	ST	02
welding	EUM	M10 x 1,50	A4 80	STANAL™400	CL27

*Standard size

Definition: all metals self-locking hexagon nut, with marking on the top of the nut

Threading: standard to ISO 965-2

Characteristic and performance test: for steel ISO 898-2/ISO 2320

for stainless steel ISO 3506-2/NF E 25-035-2

Manufacturing range: metric/inch, all diameters, coarse & fine pitch, special heights & A/F upon request

d	Pitch	h - min.	h - max.	m - min.	s
M 5	0,80	4,80	5,10	3,52	8,00
M 6	1,00	5,40	6,00	3,92	10,00
M 8	1,25	7,14	8,00	5,15	13,00
M 10	1,50	8,94	10,00	6,43	16,00
M 12	1,75	11,57	12,00	8,30	18,00
M 14	2,00	13,40	14,10	9,68	21,00
M 16	2,00	15,70	16,40	11,28	24,00
M 18*	2,50	15,80	17,00	12,70	27,00
M 20	2,50	19,00	20,30	13,52	30,00
M 24	3,00	22,60	23,90	16,16	36,00
M 27*	3,00	on request			
M 30	3,50	27,30	30,00	19,44	46,00
M 36	4,00	33,10	36,00	23,52	55,00

*These dimensions do not respond to the ISO 7042

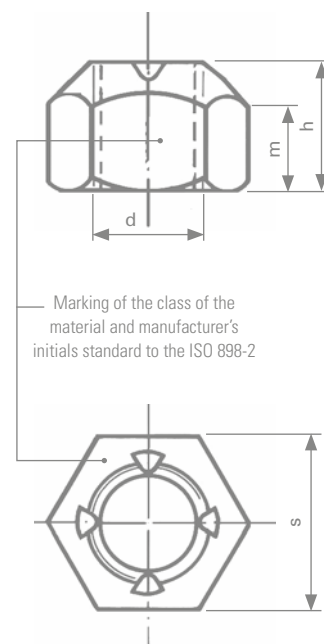

Quality class	Classification	Range of application
Class 8 steel	QV	Self color -50° C +300° C ⁽¹⁾
Class 10 steel	QK	
Class 12 steel	QL	
Stainless steel A2-70	ZE	Corrosive atmosphere -200° C +400° C ⁽¹⁾
Stainless steel A4-70	ZK	
Stainless steel A4-80	ZH	

⁽¹⁾ Values are only given as an indication

Surface treatment (standard to ROHS requirements)

Electrolytic coating (steel)	Yellow	ZJ	ISO 4042
	White LANTHANE® Finish	ZL	ISO 4042
	White LANTHANE® Finish + Top coat	ZF	ISO 4042
Zinc lamellar (steel)		on request	
Antigalling (stainless steel)	STANAL™ 400	ST	
	Sherardisation	SH	NF EN 13811
Self Color		BT	

Example of ordering code

	Type	Diam x pitch	Class	Protection	
classification	GSL	M10 x 1,50	ZH	ST	01
wording	GSL	M10 x 1,50	A4 80	STANAL™ 400	*

*Standard size

Definition: all metals self-locking hexagon flange nut
locking by deformation of the last threads given by recessions at the top of the nut

Threading: standard to ISO 965-2

Characteristic and performance test: for steel ISO 898-2/ISO 2320
for stainless steel ISO 3506-2/NF E 25-035-2

Manufacturing range: metric/inch, all diameters, coarse & fine pitch, special heights & A/F upon request



d	dc	s	h	mw
M 5	11,80	8,00	5,00	2,20
M 6	14,20	10,00	6,00	3,10
M 8	17,90	13,00	8,00	4,50
M 10	21,80	15,00	10,00	5,50
M 12	26,00	18,00	12,00	6,70
M 14	29,90	21,00	14,00	7,80
M 16	34,50	24,00	16,00	9,00
M 20	42,80	30,00	20,00	11,10

From diameter M5 to M20 (steel)
From diameter M5 to M12 (stainless steel)

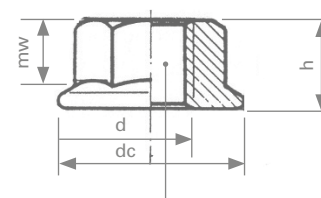

Marking of the class of the material and manufacturer's initials standard to the ISO 898-2

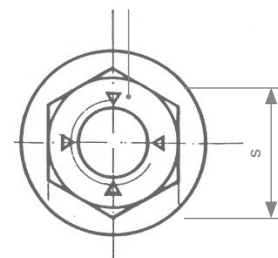

Quality class	Classification	Range of application
Class 8 steel	QV	Self color -50° C +300° C ⁽¹⁾
Stainless steel A2-70	ZE	Corrosive atmosphere -200° C +400° C ⁽¹⁾

Others: Brass - Bronze - Light alloy - Titanium...

⁽¹⁾ Values are only given as an indication

Surface treatment (standard to ROHS requirements)

Electrolytic coating (steel)	Yellow	ZJ		ISO 4042
	White LANTHANE® Finish	ZL		ISO 4042
	White LANTHANE® Finish + Top coat	ZF		ISO 4042
Zinc lamellar (steel)			on request	
Antigalling (stainless steel)	STANAL™ 400	ST		
	Sherardisation	SH	NF EN 13811	
Self Color		BT		

Example of ordering code

	Type	Diam x pitch	Class	Protection	
classification	SRF	100150	QV	ZF	00
wording	SRF	M10 x 1,50	8	White LANTHANE® Top coat	*

*Standard size

HHS HUS HMS

HFR NUT

STARNUTS

Definition: all metals self-locking hexagon nut locking by deformation of the last threads given by recessions at the top of the nut. (Marked standard to the NF EN ISO 7719/NFE 25401)

Threading: standard to ISO 965-2

Characteristic and performance test: for steel ISO 898-2/ISO 2320
for stainless steel ISO 3506-2/NF E 25-035-2

Dimensions: all forms allowed Hh H Hm: ISO 4033 Symbol Hh (high)
ISO 4032 Symbol H (regular)
ISO 4035 Symbol Hm (low)

Manufacturing range: metric/inch, all diameters, coarse & fine pitch, special heights & A/F upon request



d	Pitch	s	h HMS		h HUS		h HHS	
			min.	max.	min.	max.	min.	max.
M 3	0,50	5,50	1,55	1,80	2,15	2,40	-	-
M 4	0,70	7,00	1,95	2,20	2,90	3,20	-	-
M 5	0,80	8,00	2,45	2,70	4,40	4,70	4,80	5,10
M 6	1,00	10,00	2,90	3,20	4,90	5,20	5,40	5,70
M 8	1,25	13,00	3,70	4,00	6,44	6,80	7,14	7,50
M 10	1,50	16,00	4,70	5,00	8,04	8,40	8,94	9,30
M 12	1,75	18,00	5,70	6,00	10,37	10,80	11,57	12,00
M 14	2,00	21,00	6,45	7,00	12,10	12,80	13,40	14,10
M 16	2,00	24,00	7,42	8,00	14,10	14,80	15,70	16,40
M 18	2,50	27,00	8,42	9,00	15,10	15,80	16,90	17,60
M 20	2,50	30,00	9,10	10,00	16,90	18,00	19,00	20,30
M 22	2,50	34,00	9,90	11,00	18,10	19,40	20,50	21,80
M 24	3,00	36,00	10,90	12,00	20,20	21,50	22,60	23,90
M 27	3,00	41,00	12,40	13,50	22,50	23,80	25,40	26,70
M 30	3,50	46,00	13,90	15,00	24,30	25,60	27,30	28,60
M 33	3,50	50,00	15,40	16,50	27,40	28,70	30,90	32,50
M 36	4,00	55,00	16,90	18,00	29,40	31,00	33,10	34,70

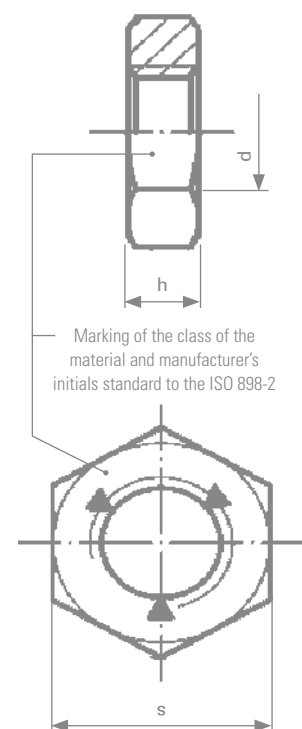

Quality class	Classification	Range of application
HMS Class 04 steel (Class 8)	QN	Self color -50° C +300° C ⁽¹⁾
HMS Class 05 steel (Class 10)	QS	
HUS/HHS Class 8 steel	QV	
HUS/HHS Class 10 steel	QK	
HMS Stainless steel A2-035	ZEB	Corrosive atmosphere -200° C +400° C ⁽¹⁾
HMS Stainless steel A4-040	ZHB	
HUS/HHS Stainless steel A2-70	ZE	
HUS/HHS Stainless steel A4-80	ZH	

⁽¹⁾ Values are only given as an indication

Surface treatment (standard to ROHS requirements)

Electrolytic coating (steel)	Yellow	ZJ	ISO 4042
	White LANTHANE® Finish	ZL	ISO 4042
	White LANTHANE® Finish + Top coat	ZF	ISO 4042
Zinc lamellar (steel)		on request	
Antigalling (stainless steel)	STANAL™ 400	ST	
	Sherardisation	SH	NF EN 13811
Self Color		BT	

Example of ordering code

	Type	Diam x pitch	Class	Protection	
classification	HUS	100150	QV	ZL	00
	HUS	M10 x 1,50	8	White LANTHANE®	*

*Standard size

Threading: standard to ISO 262/ISO 965-2

Characteristic and performance tests: ISO 2320/ISO 3506-2

Material: stainless steel A2-70

Surface treatment: stainless steel - Antigalling: - STANAL™ 400
 (Standard to ROHS requirements) - Sherardisation
 - Passivation

Field of application: contact us

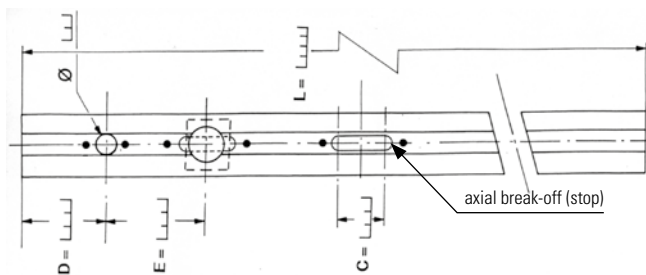

<p>Ref. 201144</p> <p>Material: AISI 304 Z6 CN 1809</p>	M3 to M5	M3 to M5 deflections	M3 to M5	M3 to M6
<p>Ref. 203010</p> <p>Material: AISI 304L Z2 CN 1810</p>	M3 to M8	M3 to M8 deflections	M3 to M8	M3 to M8
<p>Ref. 203326</p> <p>Material: AISI 304L Z2 CN 1810</p>	M6 to M12	M6 to M12 deflections	M6 to M10	M8 to M12
<p>Ref. 203048</p> <p>Material: AISI 304L Z2 CN 1810</p>	M6 to M10	M6 to M10 deflections	M6 to M8	M6 to M12



Ease of use:

- From 25 mm to 6 meters long
- Unlimited quantity of nuts and/or screws can be positioned within the channel
- Large range of diameter and material for nuts and/or screws
- Range of type of nuts and/or screws (possible combination)
- Equidistance between products
- Internal technical setup (oval holes, lights, spring mounts, prepunched rivet holes)
- Channels may be manufactured straight, bent and/or curved.

For special applications and inserts, please do not hesitate to **contact us**

Threading: standard to ISO 262/ISO 965-2

Characteristic and performance tests: ISO 2320

Material: light alloy

Surface treatment: all treatments

(Standards to ROHS requirements)

Field of application: contact us

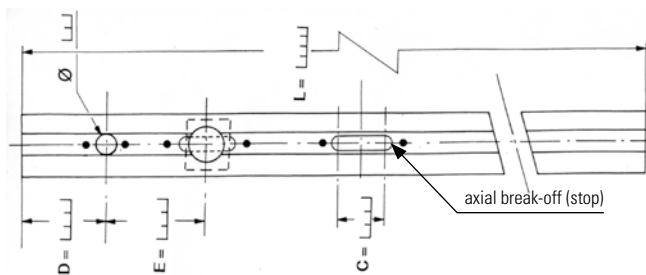

<p>Ref. 101000 Material: 6060 (AGS) T5</p>	M3 to M5	M3 to M5 deflections	M3 to M5	M3 to M6
<p>Ref. 403010 Material: 1050A (A5)</p>	M3 to M8	M3 to M8 deflections	M3 to M8	M3 to M8
<p>Ref. 403048 Material: 1050A (A5)</p>	M6 to M10	M6 to M10 deflections	M6 to M10	M6 to M12
<p>Ref. 501000 Material: 6060 (AGS) T5</p>	M6 to M10	M6 to M10 deflections	M6 to M10	M6 to M12



Ease of use:

- From 25 mm to 6 meters long
- Unlimited quantity of nuts and/or screws can be positioned within the channel
- Large range of diameter for nuts and/or screws
- Range of type of nuts and/or screws (possible combination)
- Equidistance between products
- Internal technical setup (oval holes, lights, spring mounts, prepunched rivet holes)
- Channels may be manufactured straight, bent and/or curved.

For special applications and inserts, please do not hesitate to **contact us**

SPR

HFR NUT

SPRING STOP NUT

Definition: all metals self-locking nut with metallic insert

Threading: standard to ISO 965-2

Manufacturing range: metric/inch, all diameters, coarse & fine pitch, special heights & A/F upon request



d	Pitch	da	dw - min.	h	s	E - min.
M 3	0,50	3,00 – 3,45	4,80	2,70 – 3,30	5,32 – 5,50	6,01
M 4	0,70	4,00 – 4,60	5,90	3,50 – 4,10	6,78 – 7,00	7,66
M 5	0,80	5,00 – 5,75	6,90	4,30 – 4,90	7,78 – 8,00	8,79
M 6	1,00	6,00 – 6,75	8,90	4,60 – 5,40	9,78 – 10,00	11,05
M 8	1,25	8,00 – 8,75	11,60	6,90 – 7,70	12,73 – 13,00	14,38
M 10	1,50	10,00 – 10,80	15,60	7,90 – 8,70	16,73 – 17,00	18,90
M 12	1,75	12,00 – 13,00	17,40	10,10 – 10,90	18,67 – 19,00	21,10
M 14	2,00	14,00 – 15,10	20,50	12,00 – 13,00	21,67 – 22,00	24,49
M 16	2,00	16,00 – 17,30	22,50	14,00 – 15,00	23,67 – 24,00	26,75
M 18	2,50	18,00 – 19,50	24,90	15,50 – 16,50	26,16 – 27,00	29,56
M 20	2,50	20,00 – 21,50	27,70	17,00 – 18,00	29,16 – 30,00	32,95

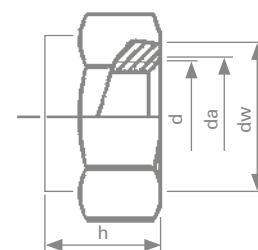

Quality class	Classification	Range of application
Class 5 steel	QF	Self color -50° C +300° C ⁽¹⁾
Class 6 steel	QJ	
Stainless steel A2-70	ZE	Corrosive atmosphere -200° C +400° C ⁽¹⁾

⁽¹⁾ Values are only given as an indication

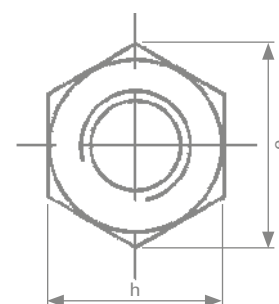

Surface treatment (standard to ROHS requirements)

Electrolytic coating (steel)	Color	Classification	ISO 4042
	Yellow	ZJ	ISO 4042
	White LANTHANE® Finish	ZL	ISO 4042
	White LANTHANE® Finish + Top coat	ZF	ISO 4042

Example of ordering code

	Type	Diam x pitch	Class	Protection	
classification	SPR	100150	QF	ZL	00
wording	SPR	M10 x 150	Steel	White LANTHANE®	*

*Standard size

SPECIAL PRODUCTS



SELF-LOCKING BUSHING NUT



CONICAL SELF-LOCKING NUT
BY HEXAGONAL
DEFORMATION



TURRET SELF-LOCKING NUT
WITH SINGLE SLOT



SLOTTED ROUND NUT

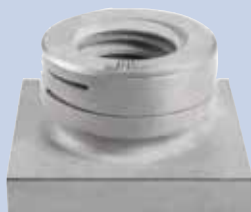

SELF-LOCKING CHANNEL NUT
DOUBLE SLOTTED



SELF-LOCKING ACORN NUT
BY AXIAL DEFORMATION



SQUARE SELF-LOCKING NUT



SELF-LOCKING ACORN NUT
WITH NYLON INSERT



NYLON INSERT CLINCH NUT



ACORN NUT WITH DISC
SPRING WASHER

SPECIAL PRODUCTS

